



**AGM Pin Welder
Instruction Manual
Model PA-15**

**AGM Industries, Inc.
16 Jonathan Drive, Brockton, MA 02301**

TEL: 800 225-9990/ 508-587-3900 FAX: 800 342-5246

www.agmind.com



Read equipment manufacturer's manual before using this product. Failure to do so can result in serious injury or death.



As is true for all types of welding equipment, serious injury may result if not properly used and maintained. Though numerous safety features are built into this welder, the users must familiarize themselves with the proper installation, usage and maintenance of the welder as outlined in this instruction manual.

In addition, the following should be observed:

1. Refer all service to qualified personnel.
2. **DO NOT** operate the welder with the cover removed.
3. **DO NOT** work with or keep welder in wet or damp areas.
4. **DO NOT** weld in the rain.
5. **DO NOT** look directly at the weld as it is taking place, as this may cause eye injury.
6. **DO NOT** touch the weld pin immediately after the weld has been made, as the pin can become very hot and may burn the skin if touched. Allow sufficient time for the pin to cool before handling it.
7. **DO NOT** weld near flammable materials or liquids, in or near areas containing explosive gases or fumes.
8. **DO** wear protective clothing when welding to prevent weld slag from contacting and burning the skin.
9. **DO** keep this manual with the welder at all times and be certain that anyone who operates the welder reads and understands this manual thoroughly.
10. **DO** wear safety glasses.
11. **DO** follow guidelines for a safe workplace.

TABLE OF CONTENTS – MODEL PA-15 WELDER

	<u>PAGE</u>
• Foreword and Warranty	4
• Description of Welding System	5
• System Operating Instructions	7
• Model 250-C Weld Gun	9
• Description of Accessories	9
• Installing and Removing Collets, Stops, etc.	11
• Installing 437G- & 250C-G Type Stops	12
• 250C-G & 437-G Type Stops Selection Sheet	13
• Installing and Removing Collet Adapter	14
• Installing or Changing Springs	15
• Disassembly of Weld Gun	16
• Illustration NO. 1	17
• Operating Suggestions	18
• Maintenance	19
Model 250-C Weld Gun Set-up Sheets	
• Welding Steel Pins	20
• Welding Aluminum CD Pins	21
• Welding Pins Over 7” Long	22
• Welding Flanged Steel & Stainless Studs up to ¼-20 Dia.	23
• Welding to Curved Surfaces	24
• Typical Template	25
• Welding Through a Template	26
• Welding 5/16-18 and 3/8-16 Studs	27
• Welding Aluminum Non-Flanged & Flanged Studs	29
• Welding Non-Flanged Steel and Stainless Steel Studs	29
• Setup for Adjustable Foot Assembly	30
• Welding Cupped Head Pins	31
• Cupped Head Pin Application Sheet	32
• Assembly & Disassembly of 437-PM	33
• Welding Powerbase and Double Pointed Pins	34
• Legend – Wiring Diagram	36
Welder Part Illustrations	
• Illustration NO. 2	38
• Illustration NO. 3	39
• Illustration NO. 4	40
• Power Pack Parts List	41

FOREWORD

The AGM Model PA-15 is the most up to date welding system in the pin and stud welding industry.

This welding system has been carefully constructed from the finest and most reliable parts available, with all components being rigidly inspected and tested to assure long and trouble free performance.

This Initial Contact Capacitor Discharge (CD) welding system requires no flux, inert gas or arc shields to weld pins or studs.

The PA-15 welding system incorporates features that make it inexpensive to operate and maintain. It will give excellent service over a long period of time with just ordinary care and maintenance.

This manual provides adequate information for the operation and maintenance of the system. If you are in need of additional application information or service, contact your AGM representative or the factory direct.

LIMITED WARRANTY

No Warranty, including warranty of merchantability, express or implied, is made in connection with the sale of this machine, except that AGM Industries will repair or replace defective parts which may develop under normal and proper use of the machine during a period of ninety (90) days from the date of delivery, provided that the warranty shall not be valid if the machine has been subjected to misuse or abuse or has not been installed, adjusted, maintained, operated, or used in accordance with instructions furnished by AGM Industries, or if pins or studs other than those manufactured by AGM Industries, even though purchased from sources approved by AGM Industries, are used with it. Notice of any claim hereunder shall be given by the purchaser to AGM Industries in writing within five (5) days after the defect shall have been discovered. AGM shall have no liability for any labor or material charge or shipping cost not expressly authorized by them in writing; and in this event, their liability shall be limited as in these conditions set forth.

DESCRIPTION OF WELDING SYSTEM

The AGM Model PA-15 Welding System is a versatile, solid state, portable pin and stud welding system designed for a variety of fastening applications. This unit is capable of welding 14 Ga. – 10 Ga. CD and Powerbase pins, CD studs up to 3/8” diameter and cup head pins, onto a metallic surface through the use of initial contact **Capacitor Discharge** (CD) welding. The welding system consists of a power pack; a lightweight weld gun, gun lead extension and ground lead, complete with a ground clamp.

The system is capable of making up to 18 welds per minute to low carbon, stainless and galvanized steel, as well as to many aluminum and copper alloys. The power pack provides the source of energy and all the necessary controls for the welding process. It also has a circuit to automatically discharge the weld capacitors through a resistor when the AC line switch is placed in the “OFF” position or the cover is removed.

The weld gun has a contoured, pistol shaped handle with a trigger button. As a safety feature, all AGM welding systems are designed so that the stud or pin must be in contact with the work piece before the weld cycle can be actuated.

When used with AGM pins or studs, this system is a most valuable and economical tool and is suited for most commercial and industrial applications.

SAFETY FEATURES

Weld Terminal Voltage Monitor

If the weld SCR shorts, this circuit will sense the capacitor voltage at the weld terminals, which in turn will actuate the main circuit breaker.

Cover interlock switch prevents welder from operating with cover removed.

NOTICE

Care must be taken to operate this welder on the rated AC line voltage range (95-130 AC) *only*. If operated on other voltages, damage may occur.

DESCRIPTION OF WELDING SYSTEM

SYSTEM SPECIFICATIONS

Model PA-15 Power Pack

Construction	16 Ga. Fabricated Steel
Dimensions	18" L 9-1/2" W 9-1/2" H
Weight	51 lbs.
Capacitance	152,000 µfd.
Input	95-130 VAC 60Hz 20 Amp
Weld Voltage	100-220 VDC
Mode of Welding	Contact
Weld Polarity	Standard or Reverse
Weldable Stud Diameter	14 Ga. Pin thru *3/8" stud
Weld Rate	Up to 18 per minute (Based on stud/pin Dia)

Model 250C Weld Gun

Type	Pistol Grip
Mode	Contact
Weight	2lbs.
Dim.	8 1/2" L x 2" D
Feed	Manual
Accuracy	.005" on Center

Accessories

Gun Lead Extension	24 Ft.
Ground Cable	26 Ft.

*** HEAVY DUTY CABLES MUST BE USED FOR 3/8" STUDS.**

WELDING OPERATION

WELDER SET UP

Set up the weld gun as described on pages 8-15 (refer to the Gun Set-Up sheets for specific details). Next, install the cables as shown below. Note that the illustration shows the gun set up for “reverse” polarity.

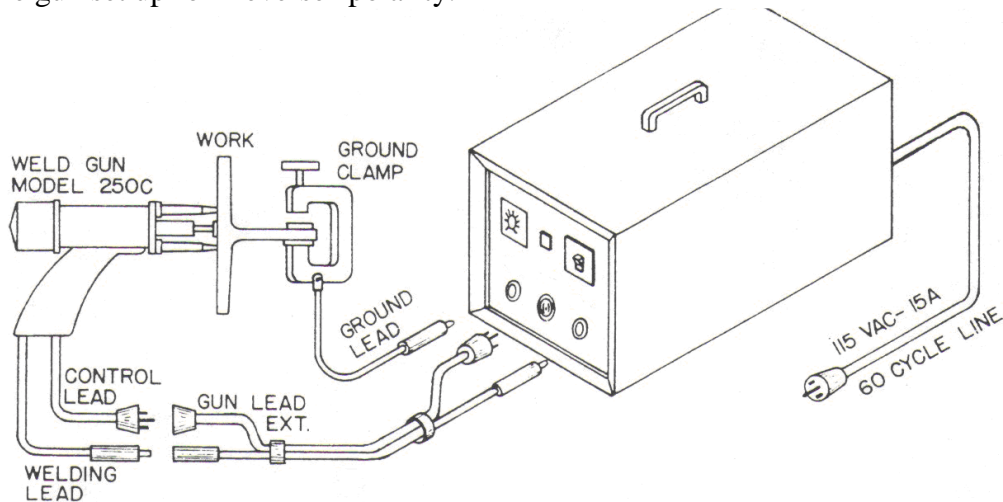

This polarity is used for welding tipped CD pins or studs to *galvanized* steel. Refer to the *Gun Set-Up Sheet* for proper ground polarity.

NOTE: Be sure all plugs are inserted fully into proper receptacles. Rotate clockwise until tight. The cables should be laid out in a straight line so that they are free of kinks, coils or sharp bends.

Proceed as follows: (*refer to Gun Set-Up Sheet for proper ground polarity*)

- 1 Insert the *ground lead plug* into the proper weld receptacle. Rotate until tight. Attach the ground clamp to clean portion of the work piece. Remove paint, rust, etc. as necessary.
- 2 Insert the *gun lead extension weld plug* into the proper weld receptacle. Rotate until tight.
- 3 Insert the *gun lead extension three-prong control plug* into the female “control” receptacle, and rotate until tight.
- 4 Insert the *three-prong control plug* of the gun into the female control connector of the gun lead extension. Rotate until tight.
- 5 Insert the *weld plug* of the gun into the female weld connector of the gun lead extension. Rotate until tight.
- 6 The *AC power lead*, attached to the rear panel of the power pack, should be plugged into a 115 VAC, 60Hz, 20 Amp power source.

The welding system is now connected and ready to operate.

WELDING OPERATION

1. Adjust the voltage control to the desired setting for your application.
2. Turn the AC line switch “on”. The green Weld Ready Light will glow within three seconds, indicating that the weld capacitors are charged and the unit is ready to weld.
3. Insert a weld stud or pin through the collet protector (when used) and into the collet. Make sure the stud/pin is inserted *as far as it will go*.
4. Position the three legs of the gun firmly against the work piece. When the stud makes contact with the work the ready light will go off.
5. Holding the gun firmly, depress the trigger switch. The power pack will then automatically control the weld cycle.
6. Once the cycle is complete, the trigger switch should be released and the gun removed from the stud/pin in a “straight line motion”. This will help avoid bent studs or pins and possible damage to the collet and protector.

It is suggested that periodic inspection of the welds be made to ensure weld strength and proper system operation.

INSPECTION OF WELDS

1. VISUAL

A good quality weld will have a minimal but even amount of splatter around the base of the stud/pin. Excessive splatter indicates that the voltage is set too high. When no splatter appears or a void exists around the base, this indicates the voltage is set too low. Adjust the voltage as necessary.

2. BEND TEST

Several test welds should be made onto a base material similar to the welding surface. The stud/pin should be bent back and forth with a piece of tubing or by striking with a hammer. Failure should occur at the shank portion of the stud/pin, *not* at the weld base. In the case of thin base metal, a plug may pull out of the base.

3. TORQUE TEST – THREADED STUDS

Make several test welds onto similar base metal. Place a few washers over the stud, and thread on a nut. Continue turning the nut until a failure occurs. The failure should be at the root diameter of the threads, *not* the weld base. In the case of thin base metal, a plug may pull out of the base.

MODEL 250-C WELD GUN

The AGM Model 250-C weld gun is a semi-automatic, contact welding tool that has been carefully engineered and designed for use with a wide variety of AGM accessories. Given normal care and use, this weld gun will require very little maintenance. When repairs are required, the complete disassembly of the weld gun can be accomplished in a matter of minutes.

Following is a description of the various accessories available. The application sheets list the recommended accessories and their part numbers.

COLLET* - This is *always* required for welding. It is very important that the correct size be used and that it is in good condition. A loose fitting collet will cause arcing on the stud or pin and could possibly cause poor welds.

COLLET PROTECTOR*- This is used when welding flanged studs or weld pins. It allows you to weld various lengths of studs or pins without changing the gun set up. It also helps to keep splatter away from the collet. It is important that the collet protector be used whenever recommended. Protectors are not required when using stops, except when welding Powerbase pins.

STOP*- This is required when welding non-flanged studs or when the adjustable foot assembly is used. Its purpose is to back up the pin or stud to prevent it from being inserted too far into the gun. The Model 250-C gun utilizes two types of stops; the 437G and the 250C-G. Both are easily installed.

COLLET ADAPTER ASSEMBLY – This is used as a holder for the collets, stops and collet protectors. It allows for rapid interchange of collets and is easily removed by the tapered wedge that is supplied with the gun.

It has been found to be good practice to keep extra collets, protectors, stops and adapters on hand.

LEGS – These are used to provide correct weld gun spring pressure while keeping the stud or pin perpendicular to the work. Legs are normally mounted 120 degrees apart on the weld gun faceplate.

LEG SUPPORT RING – This is used when welding on curved or round tanks. It is placed over the three legs and aligns the stud or pin when the ring is held firmly against the work.

* **Specify stud or pin diameter and length when ordering.**

ADAPTER RING – This is used to extend the three legs in certain applications, such as when a longer collet protector is used to weld aluminum pins.

ADJUSTABLE FOOT ASSEMBLY – This is necessary when welding very long CD pins and studs. It is used in conjunction with a stop and spark shield to stabilize the pin or stud.

SPARK SHIELD* - This protects the collet, collet adapter assembly, etc. from weld splatter, while stabilizing the pin or stud during the weld cycle. It will require occasional cleaning and periodic replacement.

***Specify stud or pin diameter and length when ordering**

MODEL 250-C WELD GUN

INSTALLATION AND REMOVAL PROCEDURES

INSTALLING COLLET AND COLLET PROTECTOR

- A. Examine the inside of the *collet adapter assembly* for pitted areas or splatter. Clean by scraping with sharp object or replace if necessary.
- B. Insert the collet into the collet adapter assembly, making sure that it seats against the inside shoulder.
- C. Rotate the retaining ring to expose the two (2) collet holding set screws and *tighten them securely*. These screws should be checked frequently for tightness.
- D. Slide the collet protector over the collet adapter assembly, making sure that it seats properly. Tighten the set screws securely.

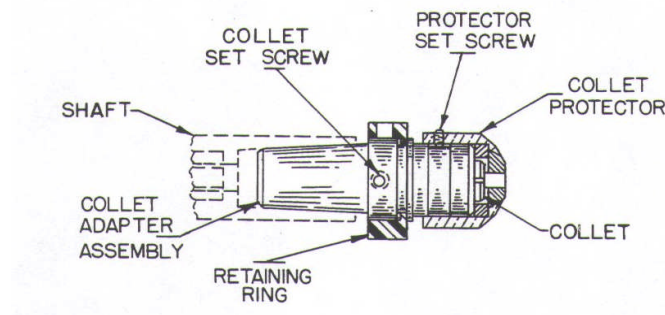

COLLET REMOVAL

- A. Remove the collet protector by loosening the two (2) protector holding set screws approximately 1-1/2 turns.
- B. Loosen both collet-holding set screws approximately 1-1/2 turns.
- C. Grasp the collet by the end, and remove.

If you have difficulty removing the collet, the following procedures may be helpful:

1. Manually rotate the collet.
2. Insert the proper size stud or pin into the collet, and attempt to remove the collet by pulling on the stud or pin.
3. If the above suggestions do not work, pliers may be used.

MODEL 250-C WELD GUN

INSTALLING TYPE 437G STOP

- A. Place stop inside the rear of the collet.
- B. Insert the collet, with stop, into the collet adapter assembly.
- C. Locate and tighten the collet holding set screws, as previously described.
- D. **Do Not** use a collet protector.

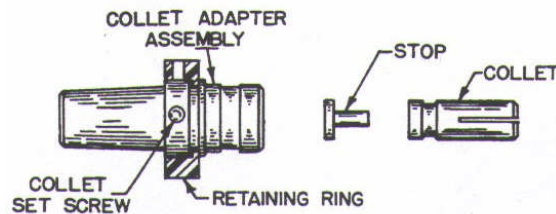

INSTALLING TYPE 250C-G STOP

- A. Remove end cap and stop nut from rear of weld gun.
- B. Insert stop inside gun shaft.
- C. Screw stop nut down securely over end of shaft.
- D. Replace end cap onto gun housing
- E. **Do Not** use collet protector.
- F. See chart on next page for stop numbers.

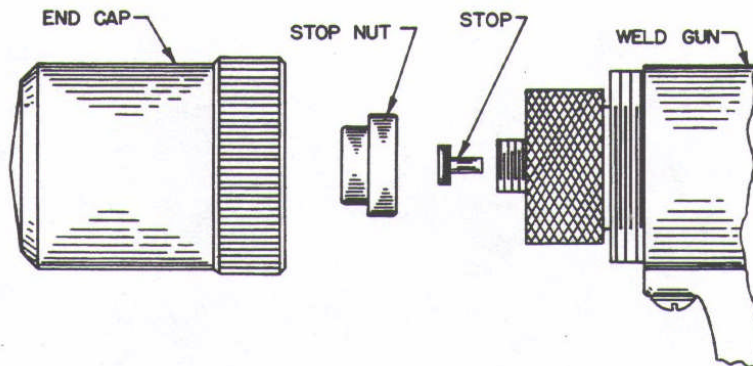

250C-G TYPE STOPS

<u>STUD LENGTH</u>	<u>CATALOG NUMBER</u>	<u>STOP LENGTH</u>
1/4" - 5/16"	250C-G-*-0250	7"
3/8" - 7/16"	-0375	6.875"
1/2" - 9/16"	-0500	6.750"
5/8"	-0625	6.625"
3/4"	-0750	6.500"
7/8"	-0875	6.375"
1"	-1000	6.250"
1-1/4"	-1250	6.000"
1-1/2"	-1500	5.750"
1-3/4"	-1750	5.500"
1-7/8"	-1875	5.375"
2"	-2000	5.250"
2-1/4"	-2250	5.000"
2-1/2"	-2500	4.750"
2-3/4"	-2750	4.500"
2-7/8"	-2875	4.375"
3"	-3000	4.250"
3-1/4"	-3250	4.000"
3-1/2"	-3500	3.750"
3-7/8"	-3875	3.375"
4"	-4000	3.250"
4-1/2"	-4500	2.750"
4-7/8"	-4875	2.375"
5"	-5000	2.250"
5-1/2"	-5500	1.750"
5-7/8"	-5875	1.375"
6"	-6000	1.250"
6-1/2"	-6500	0.750"
7"	-7000	0.250"

437G TYPE STOP

<u>STUD LENGTH</u>	<u>CATALOG NUMBER</u>	<u>STOP LENGTH</u>
** 3/16"	437G-*-0187	1.230"
** 1/4"	-0250	1.168"
** 5/16"	-0312	1.106"
** 3/8"	-0375	1.043"
7/16"	-0437	0.981"
1/2"	-0500	0.918"
9/16"	-0562	0.856"
5/8"	-0625	0.793"
3/4"	-0750	0.668"
7/8"	-0875	0.543"
1"	-1000	0.418"
1-1/8"	-1125	0.293"
1-1/4"	-1250	0.168"
1-3/8"	-1375	0.043"

*Specify diameter of stud (i.e. 6-32, 8-32, 10-32 etc.)

** Requires 375-SP series collet for studs 3/8" long and shorter.

MODEL 250-C WELD GUN

INSTALLATION OF COLLET ADAPTER ASSEMBLY

This procedure can be accomplished with a collet and stop or collet protector already installed.

- A. Before installing, be sure that the tapered surfaces of the collet adapter and shaft assembly are clean. Wipe with a clean cloth if necessary.
- B. Insert the collet adapter assembly into the shaft assembly, turning the adapter as it is pushed down. This will ensure that it is seated securely.

REMOVAL OF COLLET ADAPTER ASSEMBLY

- A. Slide the rubber dust boot toward the faceplate to expose the shaft assembly.
- B. Insert the tapered wedge between the shaft assembly and the collet adapter assembly. The flat side of the wedge should go toward the shaft.
- C. Tap the wedge lightly to release the adapter assembly from the tapered seat of the gun shaft.

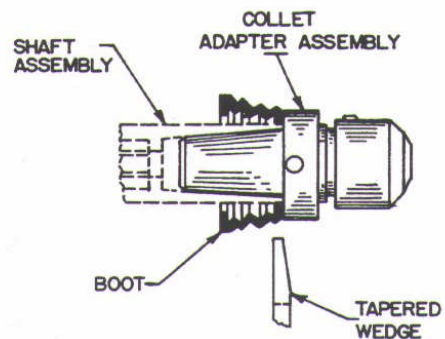

MODEL 250-C WELD GUN

INSTALLING OR CHANGING SPRING

- A. Unscrew the end cap from the gun housing.
- B. Unscrew stop nut from the end of gun shaft.
- C. Unscrew the spring retainer and remove the washer from the housing.
- D. Remove the spring from the shaft.
- E. Slide the desired spring over the shaft.
- F. Replace the washer onto the end of the gun housing.
- G. Screw the spring retainer into the housing.
- H. Screw the stop nut onto the end of the gun shaft.
- I. Screw the end cap onto the gun housing.

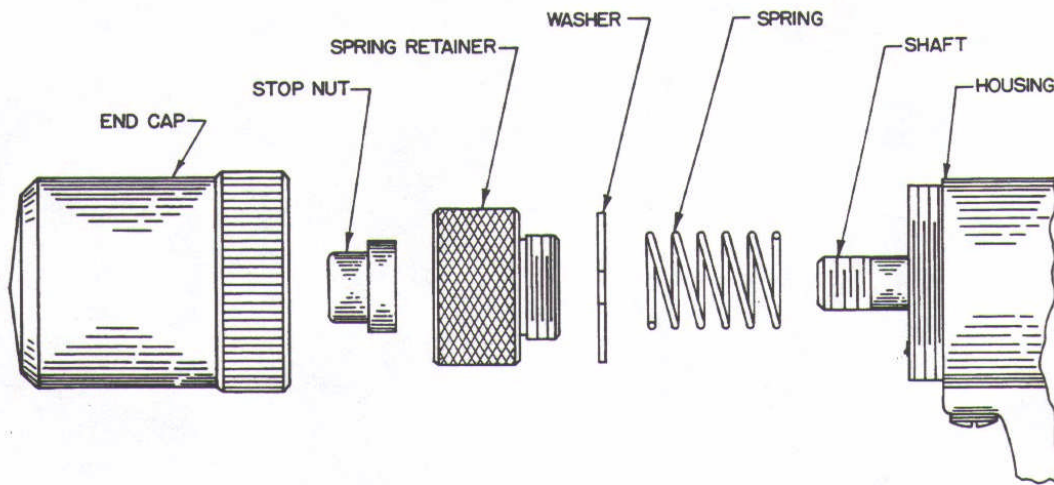

MODEL 250C WELD GUN

DISASSEMBLY OF THE WELD GUN (Refer to Illustration No. 1, page 17)

- A. Remove handle cover screws (items 28, 29, & 45).
- B. Lift off the handle cover (item 38).
- C. Remove the nut, washer, and cap screw (items 34, 35, & 36) from the welding lead (item 40).
- D. Remove the control wires (item 32, & 33) from the trigger switch (item 37), and remove the switch from the handle.
- E. Lift out the welding and control lead assemblies (item 40, & 30), from the handle.
- F. Loosen the cap screw of the cable clamp assembly (item 39), and slide both wires out of the clamp.
- G. Unscrew the end cap (item 1) from the gun housing.
- H. Unscrew the stop nut (item 15) from the end of the shaft.
- I. Unscrew the knurled spring retainer (item 17) from the gun housing.
- J. Remove the washer (item 3)
- K. Remove the spring (item 4) from the gun shaft.
- L. Unscrew the three (3) screws (item 9 & 22) from the housing.
- M. Remove the collet adapter assembly and dust boot (items 25 & 12) from the shaft assembly (item 6).
- N. Check to be sure there are no burrs on the end of the gun shaft. If necessary use a file or emery paper to smooth it off. Slide the faceplate (item 10) off shaft assembly.
- O. Slide the shaft assembly (item 6) out of the gun housing, making sure the pigtail assembly (item 7) feeds through the slot in the housing and handle.

To reassemble the gun, repeat these operations in the reverse order.

ILLUSTRATION 1

AGM STUD WELD GUN
MODEL 250C-CONTACT

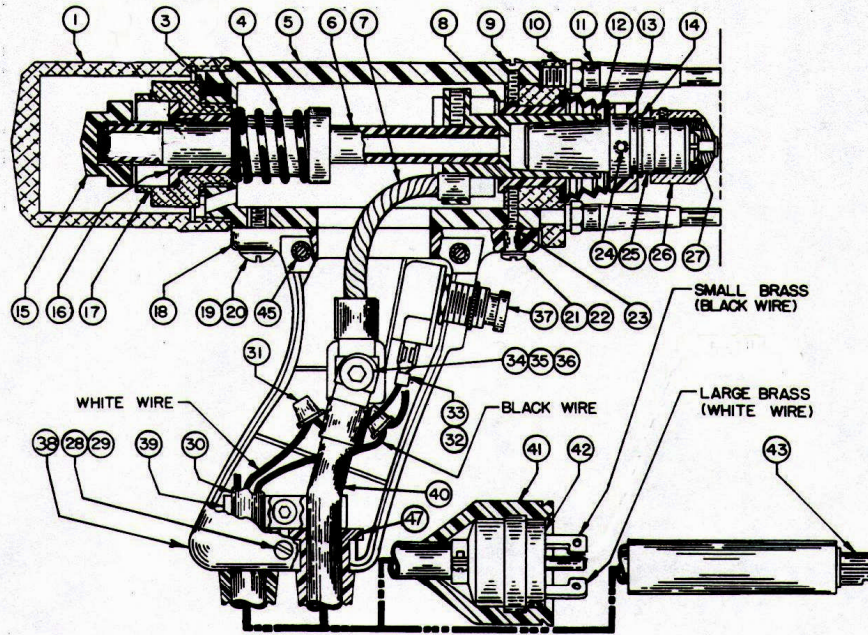

SYMBOL	PART NO.	DESCRIPTION	No. REQ'D	SYMBOL	PART NO.	DESCRIPTION	No. REQ'D
-	2500-MC	Weld Gun, Contact	1	23	2520-M	Contact, Sleeve	1
1	2501-MC	Cap, End	1	24	1204-M-312	Screw, Set	2
2				25	2513-M	Collet Adapter	1
3	2505-M	Washer	1	26	437-P**	Protector	1
4	2506-M-300	Spring (Heavy 3")	1	27	437-**	Collet	1
-	2506-M-200	Spring (Medium 2")	1	28	2004-M-1000	Nut, Sleeve	1
5	2511-M	Housing	1	29	2024-M-500	Screw, Truss Head	2
6	2507-M	Shaft Assembly	1	30	1979-E	Control Lead (Ass'y)	1
*	1213-M-250	Screw, Set	1	31	1959-E	Connector, Wire	2
7	2517-E	Pigtail Assembly	1	32	2215-EW	Switch Lead, White	1
8	2512-M	Bearing, Lower	1	33	2215-EB	Switch Lead, Black	1
9	1201-M-437	Screw, Oval Head	2	34	1216-M	Nut	1
10	2516-M	Face Plate	1	35	1217-M	Washer, Lock	1
*	1231-M-250	Screw, Set	2	36	1226-M-500	Screw, Cap	1
11	1151-M	Legs, Stationary	3	37	2117-E	Switch	1
12	1075-M	Boot	1	38	2118-MP	Handle, Cover Section	1
13	2522-M	Ring, Retainer	1	39	2165-M	Clamp Assembly	1
14	1242-M	Ring, Snap	1	40	2168-E	Welding Lead Assembly	1
15	2502-M	Nut, Stop	1	41	2720-E	Cover, Protective	1
16	2504-M	Bearing, Upper	1	42	2718-E	Cap, Male	1
17	2503-M	Spring Retainer	1	43	1047-E-RP	Plug, Male (Repair)	1
18	2108-MP	Handle, Mounting Section	1	44			
19	1230-M	Washer, Lock	1	45	2024-M-375	Screw, Truss Head	2
20	2034-M-500	Screw, Truss Head	1	46	2521-M*	Tapered Wedge	1
21	1207-M	Washer, Lock	1	47	2381-M1	Strain Relief, Weld	1
22	2024-M-750	Screw, Truss Head	1	-	2381-M2	Strain Relief, Control	1

* Not Shown

** Specify stud/pin size when ordering

(Not Shown) 2615-M ADAPTER ASSEMBLY INCLUDES ITEMS # 25, 13, 14

&24

OPERATING SUGGESTIONS

Re-check application sheet

- Do*
- Keep collet adapter assembly in good condition.
 - Make sure correct collet is in place and that the set screws are tightened securely.
 - Make sure correct protector or stop is in place.
 - Make sure the gun shaft has smooth motion.
 - Make sure legs are used when required and are tightened securely.
 - Insert pin or stud into collet until it makes firm contact with the protector or stop.
 - Hold gun perpendicular to the welding surface.
 - Hold gun steady when welding.
 - Remove gun in straight-line motion from welded pin or stud.
 - Make sure all control and weld cable connections are kept tight and clean.
 - Make sure voltage setting and ground polarity is correct for the application.
 - When used, keep spark shield as clean as possible.
- Do Not*
- Use worn or wrong size collet.
 - Use worn, broken, or wrong size protector.
 - Use wrenches or pliers on the gun shaft.
 - Use Center Punch to locate pin or stud.
 - Pull welder by cables.
 - Leave weld cables coiled up while welding.
 - Use wrong ground polarity for the application.
 - Use pins or studs not designed for use with the AGM PA-15 Welding System.

NOTICE

Care must be taken to operate this welder on the rated AC line voltage range (95-130 VACS) *only*. Failure to do so will damage the welder.

PREVENTATIVE MAINTENANCE (see note at bottom of page)

The Model PA-15 welding system has been designed to give maximum service with little maintenance. Like most equipment, however, a small amount of care and preventative maintenance is a wise investment.

To minimize down time when repairs are required, AGM recommends you always have a spare gun and cables available and in good working order.

We have listed below some of the more common items that should be checked from time to time.

1. Although the weld gun is ruggedly built, rough handling should be avoided. Check the gun shaft for damage and freedom of the “up and down” motion. The cables and plugs should also be checked for any obvious damage and repaired as required.
2. Avoid dragging the welder by the cables, as this will almost certainly damage them. Do Not put sharp bends at the connectors. Inspect them for cuts or breaks in the insulation and be sure to keep all connectors clean.
3. All louvers *must* be kept open and free from obstructions for proper air circulation inside the welder. The inside should be blown out with air or cleaned with a brush periodically.
4. Check for loose screws. (Do not over tighten capacitor screws)



Be sure to put the AC Line Switch in the “**OFF**” position and remove the line cord from the power source whenever removing the cover on the welder. Failure to do so could cause serious electric shock or injury

SET-UP FOR WELDING STEEL/STAINLESS STEEL WELD PINS

GUN SET UP WITH HEAVY (3”) SPRING

1. *12 & 10 gauge pins to galvanized steel 26 Gauge (.0217) and thicker.*
 - A. Set up the gun as described on page 8-15 of this manual. Refer to the chart below for collet and collet protector part numbers. Be sure the collet holding set screws are tightened securely.
 - B. Welding cables should be connected for “**Reverse Polarity**” (Ground to receptacle labeled **GUN**).
2. *12 & 10 gauge pins to un-plated steel or stainless steel 26 Gauge (.0187) and thicker,*
 - A. Set up gun as described above.
 - C. Welding cables should be connected for “Standard Polarity” (Ground to receptacle labeled Ground).

For welding pins over 7” in length, see page 22.

WELDER SET-UP

STEEL / STAINLESS WELD PIN	Collet / Protector	Base Material	Ground Polarity	Approximate Welding Voltage
12 Ga. (2.69mm)	437-106 437-P-106	Galvanized Steel 26 Gauge or Thicker	REVERSE	120
12 Ga. (2.69mm)	437-106 437-P-106	Un-plated Steel 26 Gauge or Thicker	STANDARD	100
10 Ga. (3.42mm)	437-135 437-P-135	Galvanized Steel 26 Gauge or thicker	REVERSE	160
10 Ga. (3.42mm)	437-135 437-P-135	Un-plated Steel 26 Gauge or Thicker	STANDARD	100

Note: Cables – Ground	1142-E (#6)
Gun Lead Extension	1279-E (#6)

WELDING PROCEDURE

Insert the weld pin into the gun and perform the weld as described in the “Welding Operation” section of this manual (page 8).

SET-UP FOR WELDING ALUMINUM WELD PINS

GUN SET UP WITH HEAVY 3” SPRING & 2367-M ADAPTER ASSEMBLY

- A. If previously installed, remove the legs (2) from gun.
- B. Install proper collet (5) and protector (4) make sure collet holding set screws are tightened securely.
- C. Place adapter ring (1) over faceplate and line up the two clearance holes with the corresponding tapped holes in the faceplate. Install the two socket head cap screws (6) and tighten securely.
- D. Insert a leg (2) into each of the three equally spaced tapped holes in the adapter ring.
- E. Slide the leg support ring (3) over the ends of the three legs. The metal inserts should face **down** toward the legs. This ring insures proper alignment of the gun when welding to curved or narrow surfaces.

NOTE: For welding pins over 7” in length, see page 22.

The gun is now ready for welding.

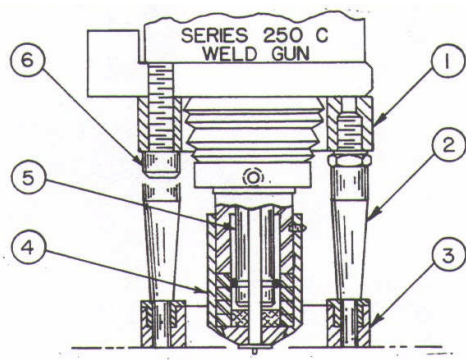

QTY.

1** Adapter Ring	1358-M-XL	1
2** Legs	1151-M	3
3** Leg Support Ring	1628-M	1
4 Collet Protector	437-P-*AL	1
5 Collet	437-*AL	1
6** Cap Screw	1212-M-0750	2

* Specify pin diameter when ordering these items.

** Part of 2367-M Adapter Assembly

WELDER SET-UP

Aluminum WELD PIN	Collet / Protector	Base Material	Ground Polarity	Approximate Welding Voltage
12 Ga. (2.69mm)	437-106AL 437-P-106AL	Embossed Aluminum	STANDARD	125
10 Ga. (3.42mm)	437-135AL 437-P-135AL	Embossed Aluminum	STANDARD	175

Note: Cables – Ground	1142-E (#6)
Gun Lead Extension	1279-E (#6)

WELDING PROCEDURE

Insert the weld pin into the gun and perform the weld as described in the “Welding Operation” section of this manual (page 8).

SET-UP FOR WELDING PINS OVER 7" LONG

GUN SET UP WITH HEAVY 3" SPRING & 2318-M FOOT PIECE ASSEMBLY

- A. Install proper collet (2); stop (1) and protector (3). Make sure collet holding set screws are tightened securely. See page 20 or 21 for part numbers.
- B. If previously installed, remove legs (1151-M) from faceplate.
- C. Insert adjustable legs (9) of foot piece assembly into the holes provided in the faceplate.
- D. Insert proper spark shield (5) into foot piece (8) and tighten set screws. (4)
- E. Insert weld pin through spark shield and into the collet, until it rests against the stop.
- F. Adjust the foot piece by loosening the two set screws (10) and sliding the assembly as required. The pin should extend beyond the spark shield approximately 1/4" as shown. Tighten the set screws securely.
- G. Check for freedom of movement between the spark shield and the weld pin. If they bind, loosen the two cap screws (6) and move the foot piece until the pin is centered in the spark shield. Once set, tighten the cap screws securely.

The gun is now ready for welding.

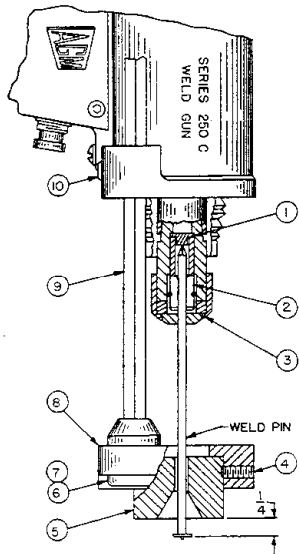

<u>LEGEND</u>	<u>DESCRIPTION</u>	<u>PART NO.</u>	<u>QTY.</u>
1	Stop	437G-1250	1
2	Collet	437-*	1
3	Collet Protector	437-P-*	1
4	Set Screw	1213-M-0500	2
5	Spark Shield	1835-M-*	1
6	Cap Screw	2000-M-1000	2
7	Washer	1993-M	2
8	Foot Piece	1999-M	1
9	Adjustable Leg	1991-M-8000**	2
10	Set Screw	1231-M-0250	2

* Specify pin diameter, length and material when ordering these items.

** For use with pins up to 8" long.
For longer pins, use the 1991-M-14000.

Items 4, 6, 7, 8 & 9 Part of 2318-M Foot Piece Assembly

WELDING PROCEDURE

Set voltage and ground polarity as directed on pages 20 and 21. Once the pins is loaded into the gun, position pin on the work piece and depress the gun until the spark shield rests on the base metal. While holding the gun firm and steady, pull the trigger.

SET-UP FOR WELDING FLANGED STEEL & STAINLESS STEEL STUDS UP TO AND INCLUDING 1/4-20 DIAMETER UP TO 7" LONG

GUN SET UP WITH HEAVY 3" SPRING

- A. Set up the gun as described on pages 8-15 of this manual, using the proper collet and collet protector. Make sure the collet holding set screws are tightened securely.
- B. Refer to the chart below for collet and collet protector part numbers.
- C. For studs that are 3/8" long and shorter, use the type 375-SP collet with appropriate stop. **Do not** use a collet protector.

WELDER SET-UP

STEEL / STAINLESS FLANGED STUDS	Collet / Protector	Base Material	Ground Polarity	Approximate Welding Voltage
4-40 (M2.8)	437-110 437-P-110	Un-plated Steel	STANDARD	100
6-32 (M3)	437-136 437-P-136	Un-plated Steel	STANDARD	100
8-32 (M4)	437-159 437-P-159	Un-plated Steel	STANDARD	115
10-24 / 32 (M5)	437-185 437-P-185	Un-plated Steel	STANDARD	130
1/4-20 (M6)	437-246 437-P-246	Un-plated Steel	STANDARD	160
Navy (3/16")	437-177 437-P-177	Un-plated Steel	STANDARD	140

Weld lead of gun lead extension plugs into weld receptacle labeled GUN.

Note: 1. Cables – Ground	1142-E (#6)
Gun Lead Extension	1279-E (#6)

WELDING PROCEDURE

Insert the weld stud into the gun and perform the weld as described in the “Welding Operation” section of this manual (page 8).

SET-UP FOR WELDING TO CURVED SURFACES

GUN SET UP

- A. Set up the gun as described on pages 11-15 of this manual, using the proper collet and collet protector or stop (if required). Tighten the collet holding set screws securely.
- B. Install the 1628-M leg support ring (2) over the three 1151-M legs (1). The metal inserts should face *down* toward the legs. This ring ensures proper alignment of the stud or pin to the work.
- C. If a leg support ring is not available, two legs may be located, 180 degrees apart, on the faceplate.

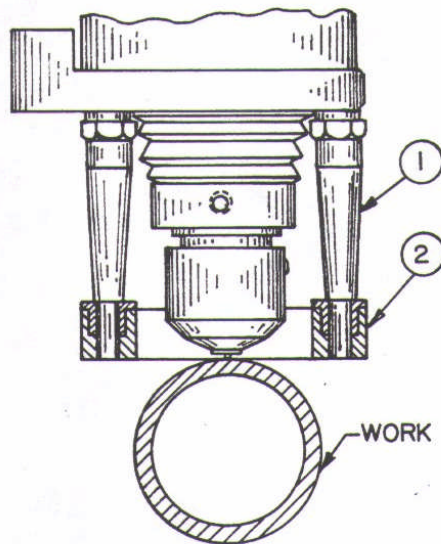

WELDING PROCEDURE

Insert the weld stud/pin into the gun and perform the weld as described in the “Welding Operation” section of this manual (page 8).

TYPICAL TEMPLATE SPECIFICATIONS

Material: Phenolic sheet

Thickness: .0125" min., .0250" max

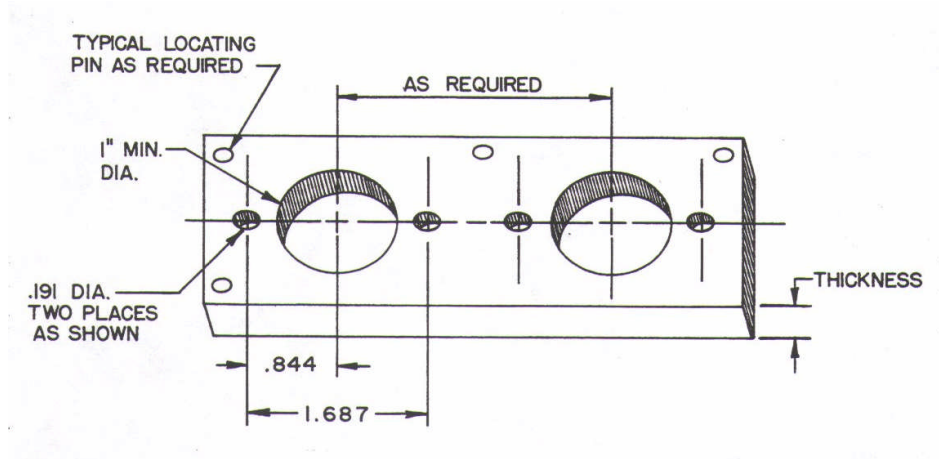

The above drawing shows the spacing and diameter of the leg location holes. The two standard 1151-M legs are inserted into these holes. To ensure that the welded stud is perpendicular to the work surface, a third leg, shortened by an amount equal to the template thickness, may be used in the weld gun. This leg is held in contact with the template during the weld cycle.

The locating pins shown are for locating from the edge of the work piece. If there are holes punched into the work piece, it may be desirable to use them for locating.

SET-UP FOR WELDING THROUGH A TEMPLATE

GUN SET UP

- A. Make a template as described on page 25.
- B. Set up the gun as described on pages 11-15 of this manual, using the proper collet and collet protector or stop (if required). Be sure the collet holding set screws are tightened securely.
- C. Install two 1151-M legs (3), 180 degrees apart in the faceplate of the weld gun.
- D. Install the third leg, which has been shortened by the thickness of the template material, into one of the remaining tapped holes (whichever is more convenient).

The gun is now ready for welding.

For correct welder set up, refer to the proper application sheet covering the stud or pin to be welded.

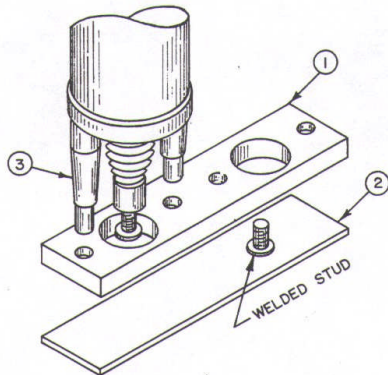

WELDING PROCEDURE

- A. Load the stud or pin into the gun as described in the "Welding Operation" section of this manual (page 6).
- B. Place the template (1) in position on the work (2).
- C. Insert both legs into the leg location holes and push down until the two legs make contact with the work. To ensure that the gun is perpendicular to the work surface, be sure that the third leg is in contact with the template.
- D. Perform the weld in the usual manner.

A typical template is shown on page 25.

SET-UP FOR WELDING 5/16-18, 5/16 SHOULDER & 3/8-16 STUDS

GUN SET-UP WITH HEAVY 3" SPRING AND 2318-M FOOT PIECE ASSEMBLY

- A. Install proper stop (1) and collet (2). Be sure the collet holding set screws are tightened securely.
- B. If previously installed, remove 1151-M legs from the face plate.
- C. Insert adjustable legs of foot piece into the holes in the face plate.
- D. Insert proper spark shield into the foot piece and tighten set screws.
- E. Insert stud through spark shield and into the collet until it rests against the stop.
- F. Check for freedom of movement between the spark shield and the stud. If they bind, loosen the two cap screws and move the foot piece until the stud is centered in the spark shield. Tighten the cap screws.
- G. Adjust the foot piece by loosening the two set screws and sliding the assembly as required. The stud should extend beyond the spark shield approximately 1/4" as shown. Tighten the set screws.

The gun is now ready for welding.

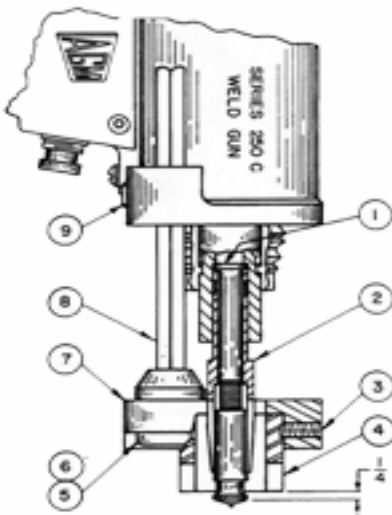

	DESCRIPTION	PART NO.	QTY.
1.	Stop	437-G-*	1
2.	Collet	437-**	1
3.	Set Screw	1213-M-0500	2
4.	Spark Shield	2144-M-*	1
5.	Cap Screw	2000-M-1000	2
6.	Washer	1993-M	2
7.	Foot Piece	1999-M	1
8.	Adjustable Leg	1991-M-8000	2
9.	Set Screw	1231-M-0250	2

* See notes 2 & 3 on next page for part numbers.

** See chart on next page for part numbers.

Items 6,7,8 & 9 are part of 2318-M Assembly.

CONTINUED

SET-UP FOR WELDING 5/16-18, 5/16 SHOULDER & 3/8-16 STUDS
CONTINUED

WELDER SET-UP

Weld Stud Size & Material	Collet	Base Material	Ground Polarity	Approximate Welding Voltage
Steel/Stainless Non-Flanged 5/16-18(M8)	437-S-307	Unplated Steel Galvanized Steel	Standard Reverse	185 195
Aluminum Non-Flanged 5/16-18 (M8)*	437-S-307	Aluminum	Standard	205
Steel/Stainless Flanged 5/16-18 (M8)	437-S-307	Unplated Steel	Standard	205
Steel/Stainless SL5/16-Shoulder	437-S-312	Unplated Steel	Standard	190
**Steel/Stainless Non-Flanged 3/8-16 (M10)	437-S-370	Unplated Steel	Standard	210

Notes:

- * 5/16-18 aluminum studs must use the 2506-M-200 spring.
To weld aluminum studs on to small pieces use of special grounding techniques may have to be used. Please consult the factory.
- ** #3/8 Studs must be non-flanged

1. Stop Requirements

- A. For all SL-5/16 shoulder studs use 437-SG-1375.
- B. For 5/16-18 and 3/8-16 studs over 1” use 437-SG-1000.
- C. For studs shorter than 1” specify stud length.

2. Spark Shields Requirements

- A. For all Studs 2 1/2” and shorter use 2144-M-250.
- B. For studs over 2 1/2” use 2144-M-300- Diameter.
Specify stud diameter when ordering this spark shield.

3. Cables

Standard cables (1142-E ground and 1279-E gun lead extension) are used for all applications with the exception of **3/8 applications**. Heavy duty cables must be used for these. 1506-E gun lead extension and 1507-E ground. See weld set up chart on welder.

SET-UP FOR WELDING FLANGED & NON-FLANGED ALUMINUM & NON-FLANGED STEEL / STAINLESS STEEL STUDS THROUGH 1/4-20 DIAMETER

GUN-SET UP WITH HEAVY 3” SPRING

- A. Set up the gun as described on page 11-15 of this manual, using the proper collet and stop. Be sure the collet holding set screws are tightened securely. **Do not** use a protector.
- B. Refer to the chart below for collet part numbers. For studs 3/8” long or shorter, use the type 375-SP collet.
- C. Use the type 437G-* stop for studs up to 1-3/8” long, and type 250C-G-* for studs over 1-3/8” long. See the next page for an **alternate set up** for welding studs over 1-3/8” long.

*Specify stud length and diameter when ordering stops.
See Chart on page 13

WELDER SET-UP

STUD SIZE	Stud Material	Collet	Ground Polarity	Welding Voltage	
				Flanged	Non-Flanged
6-32	Aluminum	437-136	STANDARD	110	110
8-32	Aluminum	437-159	STANDARD	150	120
10-24 & 10- 32 Navy Stud	Aluminum	437-185	STANDARD	160	130
	Aluminum	437-177	STANDARD	160	130

4-40	Steel / SS	437-110	STANDARD	See Page 23	100
6-32	Steel / SS	437-136	STANDARD		105
8-32	Steel / SS	437-159	STANDARD		115
10-24& 10- 32	Steel / SS	437-185	STANDARD		130
¼-20	Steel / SS	437-246	STANDARD		140

Gun Lead Extension plugs into weld receptacle labeled GUN

Note: 1. Ground Cables	1142-E (#6)
Gun Lead Extension	1279-E (#6)

- 2. For alternate gun set up to weld studs longer than 1-3/8”, see page 30.

WELDING PROCEDURE

Insert the weld stud into the gun and perform the weld as described in the “Welding Operation” section of this manual (page 8).

ALTERNATE GUN SET-UP FOR STUDS OVER 1-3/8" LONG

GUN SET-UP WITH HEAVY 3" SPRING & 2318-M FOOT PIECE ASSEMBLY

- A. Install proper stop (1), collet (2) and protector (3). Make sure the collet holding set screws are tightened securely. See the chart below and on previous page for part numbers.
- B. If previously installed, remove the 1151-M legs from the faceplate.
- C. Insert adjustable legs (9) of foot assembly into the holes provided on the faceplate.
- D. Insert the proper spark shield (5) into the foot piece (8) and tighten the set screws (4).
- E. Insert the stud through the spark shield, protector and into the collet, until stud rests against the stop.
- F. Check for freedom of movement between the spark shield and the stud. If they bind, loosen the two cap screws (6) and move the foot piece until the stud is centered in the spark shield. Once done, tighten the cap screws securely.
- G. Adjust the foot piece by loosening the two set screws (10) and sliding the assembly as required. The stud should extend beyond the spark shield approximately 1/4" as shown. Once done, tighten the set screws securely.

The gun is now ready for welding.

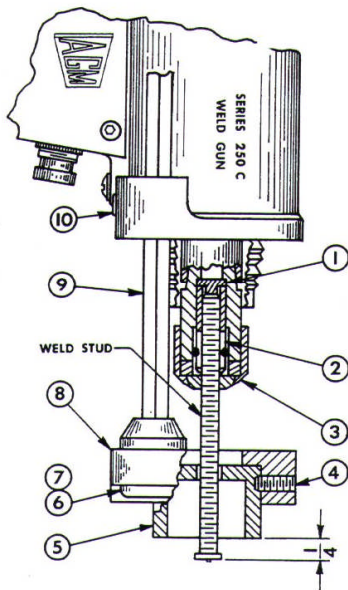

<u>LEGEND</u>	<u>DESCRIPTION</u>	<u>PART NO.</u>	<u>QTY.</u>
1	Stop	437G-1250	1
2	Collet	437-*	1
3	Collet Protector	437-P-*	1
4	Set Screw	1213-M-0500	2
5	Spark Shield (For studs 2-1/2" long & under)	2144-M-250	1
	(For studs over 2-1/2" long)	2144-M-300-*	1
6	Cap Screw	2000-M-1000	2
7	Washer	1993-M	2
8	Foot Piece	1999-M	1
9	Adjustable Leg	1991-M-8	2
10	Set Screw	1231-M-0250	2

* Specify stud diameter and length when ordering these items.

Items 4, 6, 7, 8 & 9 are part of 2318-M Foot Piece

SET-UP FOR WELDING CUPPED PINS IN THE FIELD
GUN SET-UP WITH LIGHT 1-1/4" SPRING

- A. If previously installed, remove the three 1151-M legs, as they will interfere with the proper gun shaft movement.
- B. Install the 2506-M-125 light spring as instructed on page 15 of this manual.

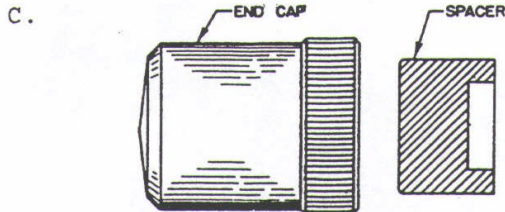

Install spacer (2525-M) inside the end cap, as shown, then screw the end cap back onto the housing.

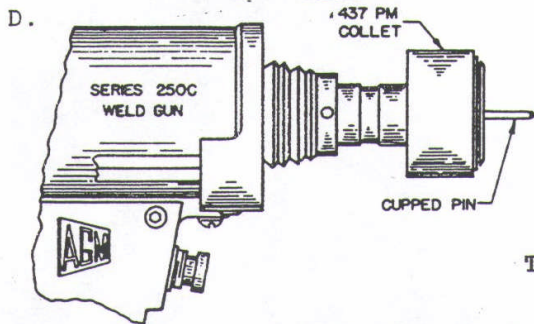

Insert magnetic collet into the collet adaptor assembly in the same manner as a regular collet, and tighten the set screws securely.

The gun is now ready for welding.

THIS SET UP IS FOR WELDING TO 22 GA. (.033") AND THICKER MATERIAL. DO NOT TRY TO WELD THROUGH PAINT OR RUST!

Pin Diameter	Collet	Base Material	Ground Polarity	Approximate Welding Voltage
14 Ga. (2.03mm)	437-PM 437-MC-M	Galvanized And un-plated Steel – 22 ga. (.033) And heavier	STANDARD	130
12 Ga. (2.63mm)	437-PM 437-MC-M		STANDARD	160
10 Ga. (3.42mm)	437-PM 437-MC-M		STANDARD	210

Note: 1. Cables – 1279-E and 1142-E (standard #6 weld cables) *Consult factory for use of additional lengths.*

WELDING PROCEDURE

Place a cupped pin against the face of the magnetic collet (437-PM or 437-MC-M), taking care that the head is centered on the collet. Push the pin through the insulation until the gun shaft is fully depressed. While holding the gun firmly and perpendicular, activate the weld cycle. If the weld cycle does not activate, check that the weld ready light is off, rotate the gun to break through scale and re-activate the weld cycle. To insure consistently satisfactory welds it is important that the gun be held firmly, but **not** forced against the work.

CUPPED PIN APPLICATION RECOMMENDATIONS

3 lb. Density Insulation and under:

In most cases, the pin should be 1/8" shorter than the insulation thickness. In the case of long fiber 3 lb. density insulation the pin may need to be the same length as the insulation thickness.

6 lb. Density Rigid Fiberglass Board:

In most cases, the pin should be 1/8" longer than the insulation thickness.

6 lb. to 9 lb. Density Wool Blanket:

Although the density is high, the wool blanket will compress easily; therefore the pin can be up to 1/2" shorter than the insulation thickness.

Calcium Silicate Block:

The pin should be 1/8" longer than the thickness of the block. This material **must** be pre-drilled with a 1/4" diameter drill wherever you want to locate a pin. In addition to being very difficult to push a pin through the block, a great deal of material collects around the end of the pin. This interferes with the weld, hence the pre-drilling. After the pins are welded in place, cement is normally grouted around the head of the pin.

Foiled Faced Insulation – Vapor Barrier:

When applying foil faced insulation, you **must use** insulated cupped head pins. If **insulated** pins are not used, arcing will take place between the head of the pin and the foil facing of the insulation, damaging the vapor barrier. AGM insulated cupped pins are furnished with an insulator disc adhered to the underside of the washer. Be sure to specify "**insulated**" when ordering.

Metallic Mesh – Faced Insulation:

When welding through insulation with a metal mesh covering (such as chicken wire, hardware cloth, perforated metal, expanded metal, etc.), **insulated** cupped pins should be used as in the above application. If **insulated** pins are not used, the pin head will arc across to the metal mesh. In cases where the pin must be put through a small diameter opening in the mesh or perforated metal, we recommend the **additional** insulation of the pin shank to prevent arcing, if should it touch metal.

437-PM MAGNETIC COLLET
INSTRUCTIONS FOR REPLACEMENT OF WORN OUT COLLET PARTS

The 437-PM-RK Repair Kit should be used to rebuild the 437-PM Magnetic Collet. It includes the following: 437-PM-1 Collet Insert, 437-PM-2 Cap Screw, 437-PM-7 Insulator Disc, 437-PM-4 Screw Sleeve Insulator, as well as the proper size Allen Wrench.

1. Remove the collet from the gun shaft.
2. Loosen and remove the 437-PM-2 Cap Screw.

IMPORTANT: Do not try to loosen the cap screw while the collet is still in the gun shaft, as this could damage internal parts of the weld gun.

3. Remove the worn Collet Insert, Part No. 437-PM-1. Note that when the cap screw is removed, the 437-PM-3 Collet Stem is now detached from the magnet.
4. Place the new parts of the Repair Kit into the magnet.
5. Screw the 437-PM-3 Collet Stem onto the cap screw. A new collet stem should be used **only if needed**. (Note that this part is not included in the repair kit, and must be purchased separately). While holding the stem firmly, insert the Allen Wrench into the cap screw and tighten securely.

IMPORTANT: Make sure the cap screw is tight, otherwise arcing and burning may take place. This will result in the parts being damaged unnecessarily. This screw should be checked periodically for tightness. Also, be sure all insulating discs and sleeves are in their proper position, as shown in the sketch below. If not the holding power of the magnet will be affected.

6. Replace the collect in the gun shaft; **BE SURE** to check the collet holding set screws for tightness frequently. They must be kept tight to prevent arcing inside the gun shaft.

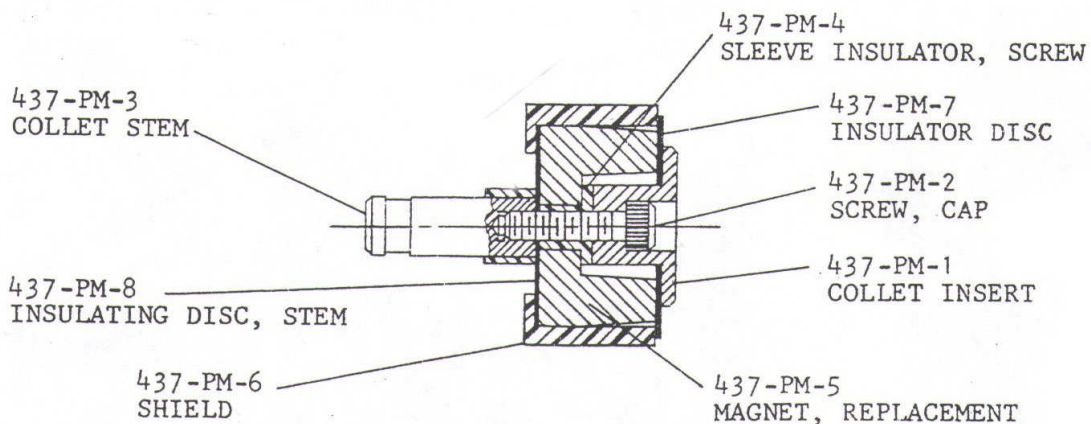

SET-UP FOR WELDING POWERBASE AND DOUBLE POINTED PINS
GUN SET UP WITH LIGHT SPRING (1-1/4") AND 2318-M FOOT PIECE
ASSEMBLY

The set up listed below is for pins **2-1/2"** and **longer**. For pins less than 2-1/2" see note on next page.

- A. Install the 2506-M-125 light spring as instructed on page 15 of this manual.
- B.

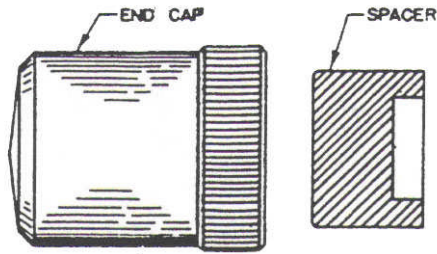

Install the 2525-M spacer inside the end cap, as shown, then screw the end cap back on the housing

- C. Install stop (1), collet (2) and protector (3). Tighten set screws. Refer to the chart on the next page for collet and protector part numbers.
- D. If previously installed, remove the 1151-M stationary legs from the face plate.
- E. Insert the adjustable legs (9) into the holes in the face plate.
- F. Insert the proper spark shield (5) into the foot piece and tighten set screws. Install with the flat surface facing away from the gun as shown on next page.
- G. Insert the pin through the spark shield and into the collet until it rests against the stop.
- H. Check for freedom of movement between the spark shield and pin. If they bind loosen the two cap screws (6) and move the foot piece until the pin is centered in the spark shield. Tighten the cap screws.
- I. Adjust the foot piece for proper pin protrusion by loosening the two set screws (10) and sliding the assembly as required. The pin should extend beyond the spark shield 3/8" to 1/2" for 12 gauge pins and 5/8" to 3/4" for 10 gauge pins, as shown on the next page. Tighten set screws.

The gun is now ready for welding.

SET-UP FOR WELDING POWERBASE PINS AND DOUBLE POINTED PINS

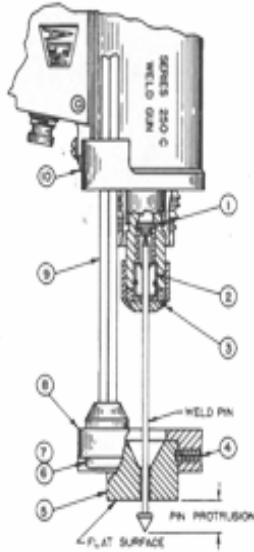

<u>LEGEND</u>	<u>DESCRIPTION</u>	<u>PART NO.</u>	<u>QTY.</u>
1	Stop	437G-1250	1
2	Collet	437-*	1
3	Collet Protector	437-P-*	1
4	Set Screw	1213-M-0500	2
5	Spark Shield	1835-M-*	1
6	Cap Screw	2000-M-1000	2
7	Washer	1993-M	2
8	Foot Piece	1999-M	1
9	Adjustable Leg	1991-M-8**	2
10	Set Screw	1231-M-0250	2

* Specify pin diameter, length and material when ordering these items.

** For use with pins up to 8" long. For longer pins, use 1991-M-14.

WELDER SET UP

Items 4,6,7,8,9&10 Part of 2318-M Adjustable Foot Assy.

Steel/ Stainless Powerbase Pin	Collet Protector	Polarity	Voltage
12 Gauge (2.69mm)	437-106 437-P-106	Standard	150
10 Gauge(3.42mm)	437-135 437-P-135	Standard	200

CAUTION: DO NOT USE POWERBASE PINS ON METAL LESS THAN 1/16" THICK.

WELDING PROCEDURE

Insert the weld pin and place it against the welding surface. Push the gun down until the shaft is fully depressed. Then, while holding the gun firmly and perpendicular to the weld surface, actuate the weld cycle. If the cycle does not initiate the gun should be rotated around the weld point in order to penetrate surface scale, paint etc. Then actuate the weld cycle again.

Note: The 2318-M adjustable foot piece is not required when welding Powerbase and double pointed pins shorter than 2-1/2". For these pins use proper collet, protector and stop. For 2" pins use 437-G-1250 stop and 1" pin use 437-G-0750 stop.

WIRING DIAGRAM LEGEND – MODEL PA-15

<u>SYMBOL</u>	<u>PART NUMBER</u>	<u>DESCRIPTION</u>
C8	3087-E	Capacitor, Welding
CB1	2475-E	Line Switch/Circuit Breaker
CB1-A&B	Part of 2475-E	Switch only
CB1-C	“ “ “	SCR Voltage Sensor
CB2	3081-E	Circuit Breaker, 20 Amp
C2	2267-E	Capacitor
DR	3074-E	Relay, Discharge
GB	2117-E	Switch Gun Trigger
L1	2295-E	Light, Weld Ready
L2	2420-E	Light, Power
PC1	2487-E-J1	Printed Circuit Board
R16	3104-E	Potentiometer, Voltage Control
R18	2567-E	Resistor, Discharge
SN1	3101-E	Snubber Capacitor
SCR2	2415-E	SCR, Weld
T1	2620-E	Transformer, Weld
V1	2398-E	Transient Suppressor
M	1255-E	Fan

Illustration No. 2

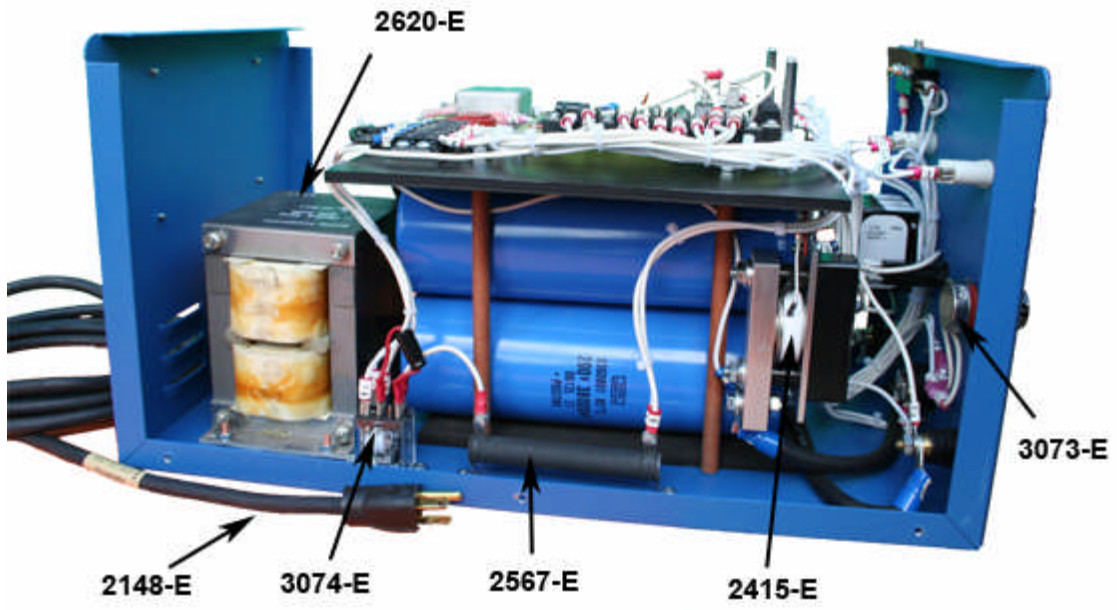
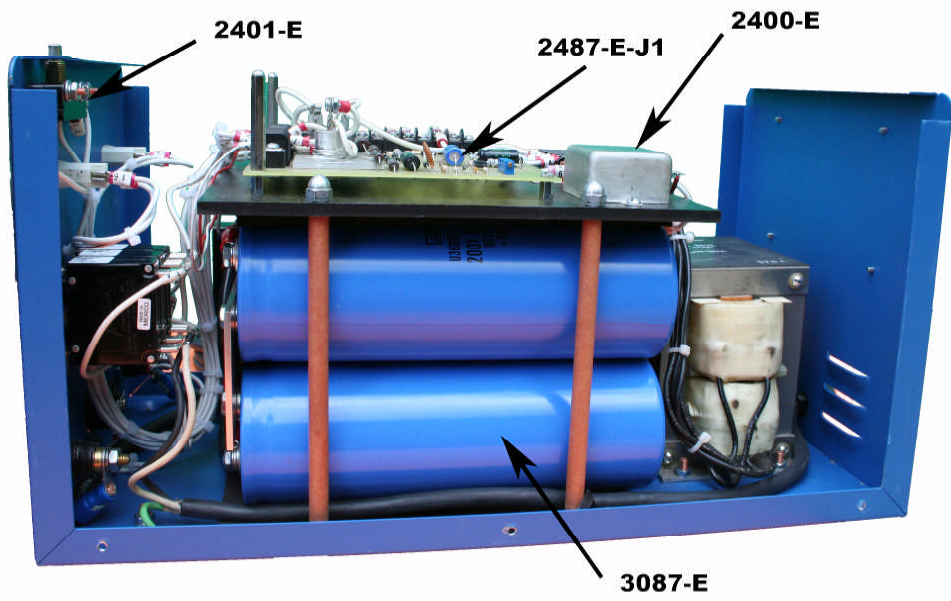

Illustration No. 3



Illustration No. 4



PA-15 POWER PACK PARTS LIST

<u>PART NO.</u>	<u>QUANTITY</u>	<u>DESCRIPTION</u>
1046-E	2	Receptacle, Weld
1086-M	1	Name Plate
1107-E	1	Receptacle, AC Control
1255-E	1	Fan
1434-E-6	1	Terminal Strip
2079-M-0375	8	Screw, Cover
2148-E	1	Line Cord
2253-E	1	MOV
2295-E	1	Light Weld Ready
2300-M	1	Handle
2312-M	1	Fan Guard
2394-M-JS1	1	Weld Set Up Chart
3101-E	1	Snubber Capacitor (Replacement)
2401-E	1	Switch Cover Interlock
2416-E	1	Clamp SCR
2420-E	1	Light Power
2425-E	1	Heat Sink SCR
2475-E	1	AC Line Switch (CB1)
2487-E-J1	1	Printed Circuit Board (PC1)
2567-E	1	Resistor, Discharge
2620-E	1	Transformer, Weld T1
3104-E	1	Potentiometer
3074-E	1	Relay, Discharge
3077-M	1	Cord Grip
3081-E-20	1	Circuit Breaker (CB2)
3087-E	4	Capacitor, Welding
3091-M1	1	Chassis Painted
3092-M	1	Cover Assembly
3093-M	1	Mounting Board P.C.
3094-E	1	Heat Sink
3098-M	1	Front Panel

NOTES

Welder Serial Number _____

Gun Serial Number _____

AGM Industries, Inc. 16 Jonathan Drive, Brockton, MA 02301
Telephone: 1 (800) 225-9990 FAX: 1 (800) 342-5246
www.agmfasteners.com